

Alabama's Internet2 and Advanced Networking Infrastructure

David Cordes, UA

David Shealy, UAB

Sara Graves, UAH

David McGirt, ITC^Deltacom





Presentation Overview

- 10 minutes: Project Overview**
David Shealy
- 8 minutes: ITC^Deltacom industrial partnership**
David McGirt
- 4 minutes: UAH campus overview**
Sara Graves
- 4 minutes: UAB campus overview**
David Shealy
- 4 minutes: UA campus overview**
David Cordes



Project Overview

David Shealy
dls@uab.edu





Gulf Central Gigapop Project Team

UA: David Cordes, John Watters, Priscilla Hancock

UAB: David Shealy, Sheila Sanders, Jill Gemmill,
Stan McClellan, Joyce Iannuzi, Landy Manderson

UAH: Sara Graves, Dan Rochowiak, Sandra Redman
Frank Gossett

What is the Gulf Central GigaPOP?

- A cooperative effort by UAB, UAH, and UA, each awarded NSF funds for high performance networks
- A working committee comprised of four to six faculty and staff from each campus, including grant PI's and local campus Telecommunications/Network services

Goals for GCG

- High-performance statewide network
 - Support research, education, and economic development (regional growth)
 - Set pace for Information Technology in AL
- Access to Next Generation Internet
 - Peer with national & regional initiatives
 - Provide network with capability to support “QoS” (differentiated service)

Internet2 gigaPOPs

(as of Mid-1998)

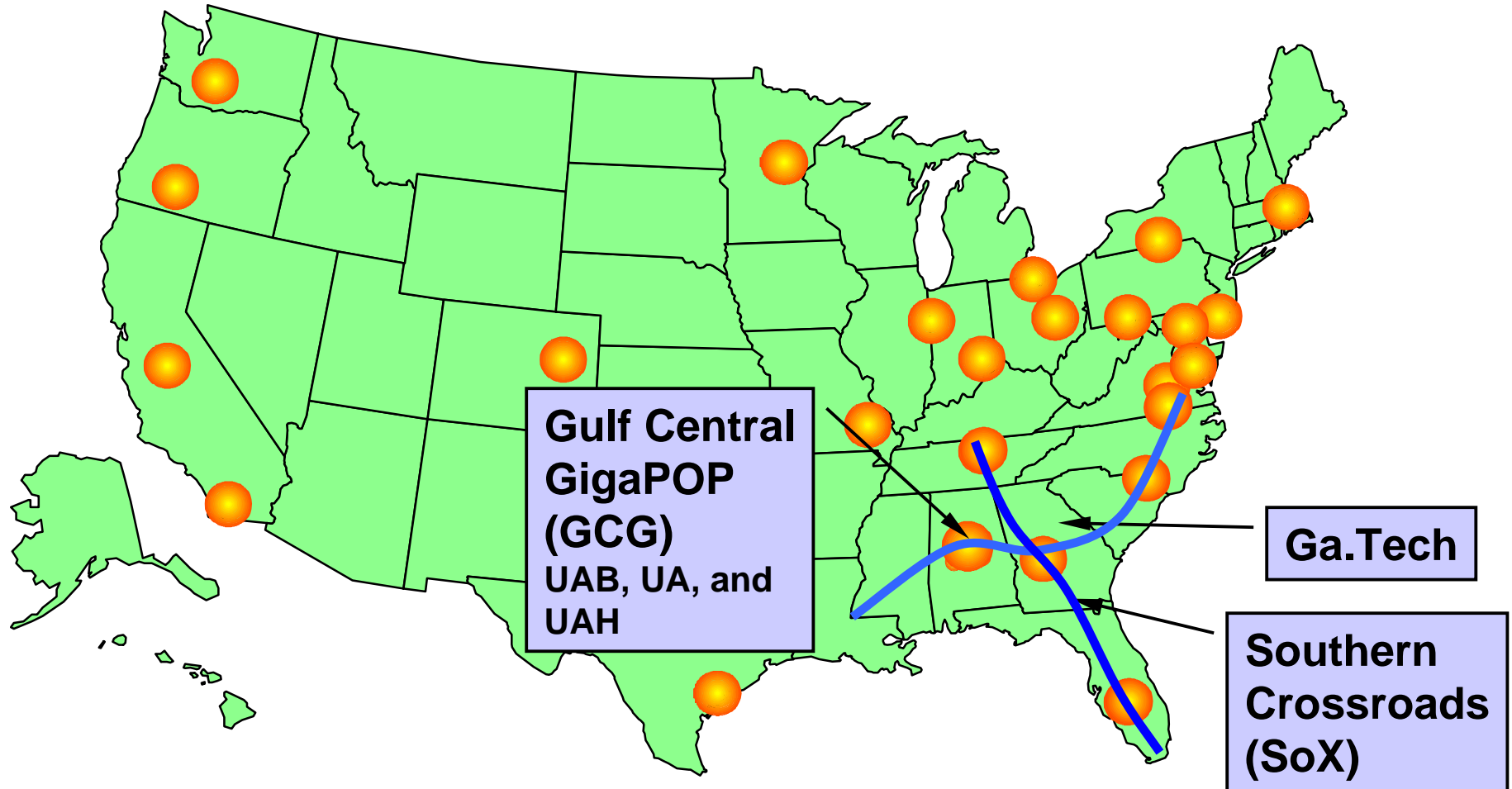

The Alabama Connection

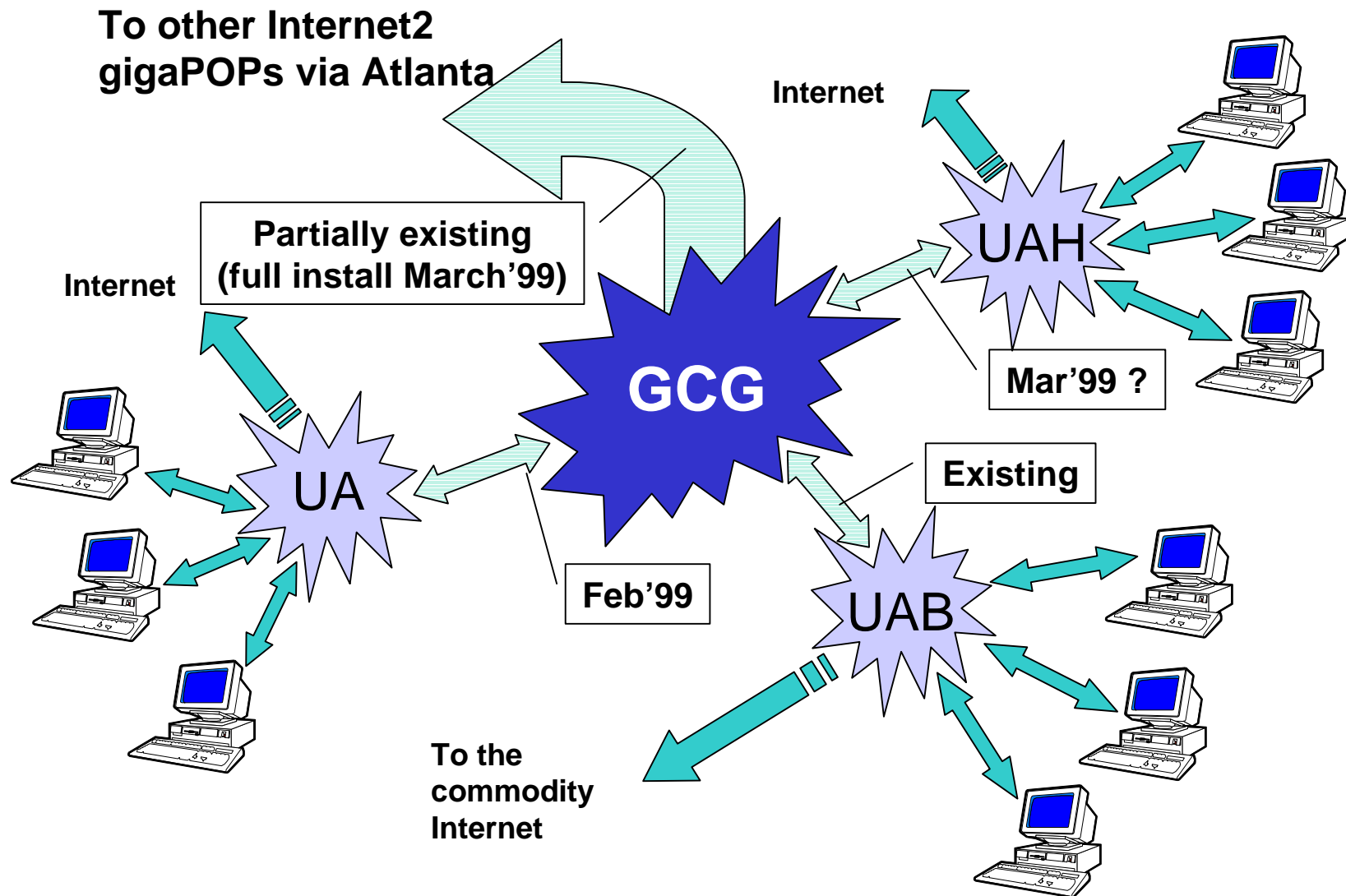

Gulf Central GigaPOP

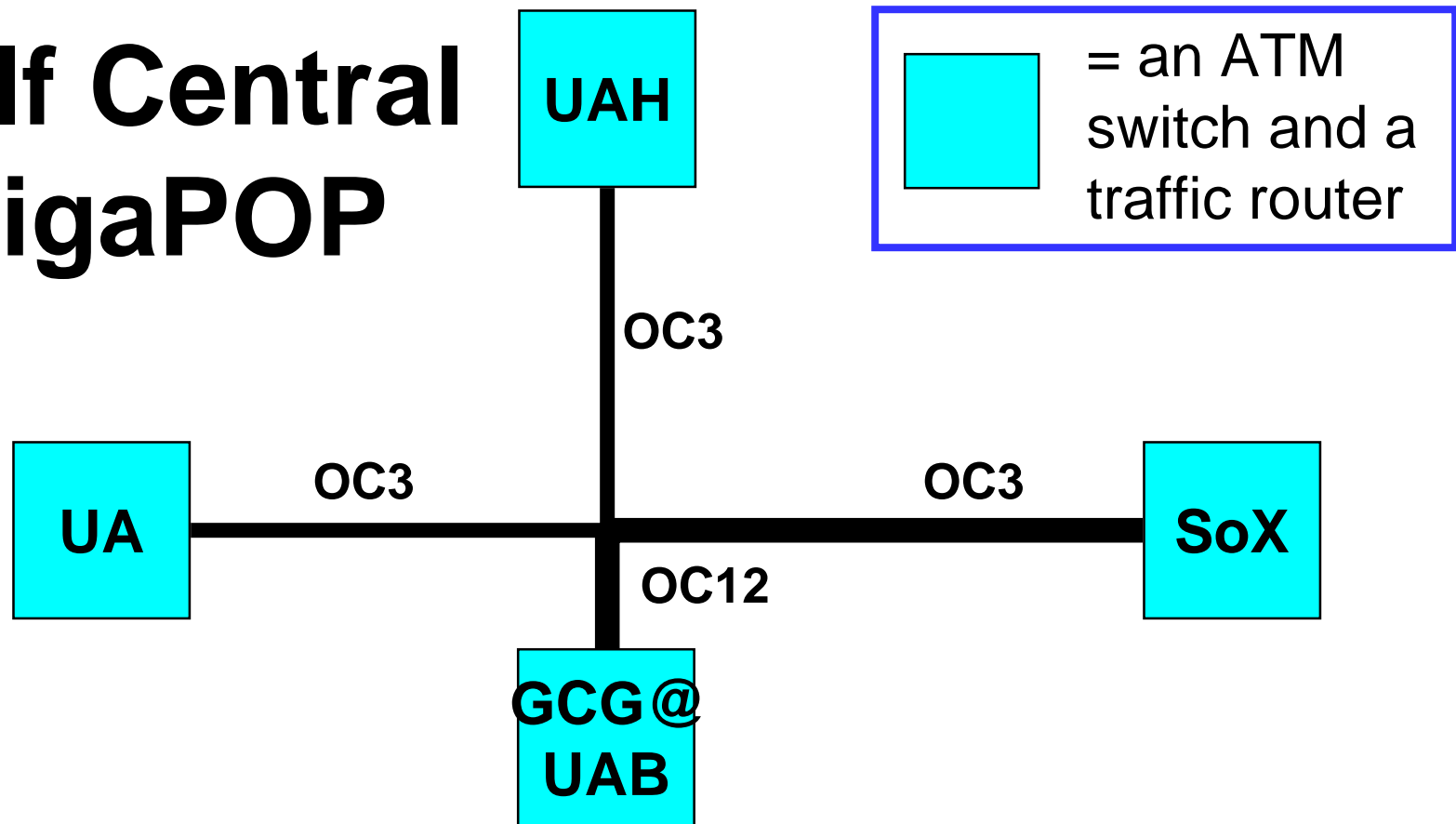

Commodity Internet : T1 = 1.5 Mb/s

Interim Connection: DS3 = 45 Mb/s

GCG Connections: OC3 = 155 Mb/s

Summary of Accomplishments

FUNDED GRANTS

- Two NSF vBNS grants
- Alabama EPSCoR Cooperative Agreement

GULF CENTRAL GIGAPOP

- UA/UAB/UAH coordination
- RFP developed
- 5 year contract signed with ITC^DeltaCom for OC3/OC12 network
- Memo of understanding being signed with AREN for operation of network operations center

Applications Working Group

- The first year has been spent obtaining necessary funding and working to get basic infrastructure in place.
- Now it is time to make known the availability of high performance networking and potential benefits to research and teaching activities.



ITC  ***DELTA*COM**

Industrial Partnership



David McGirt
dmcgirt@itcdeltacom.com



ITC^DeltaCom Network Map & Internet 2 Schools

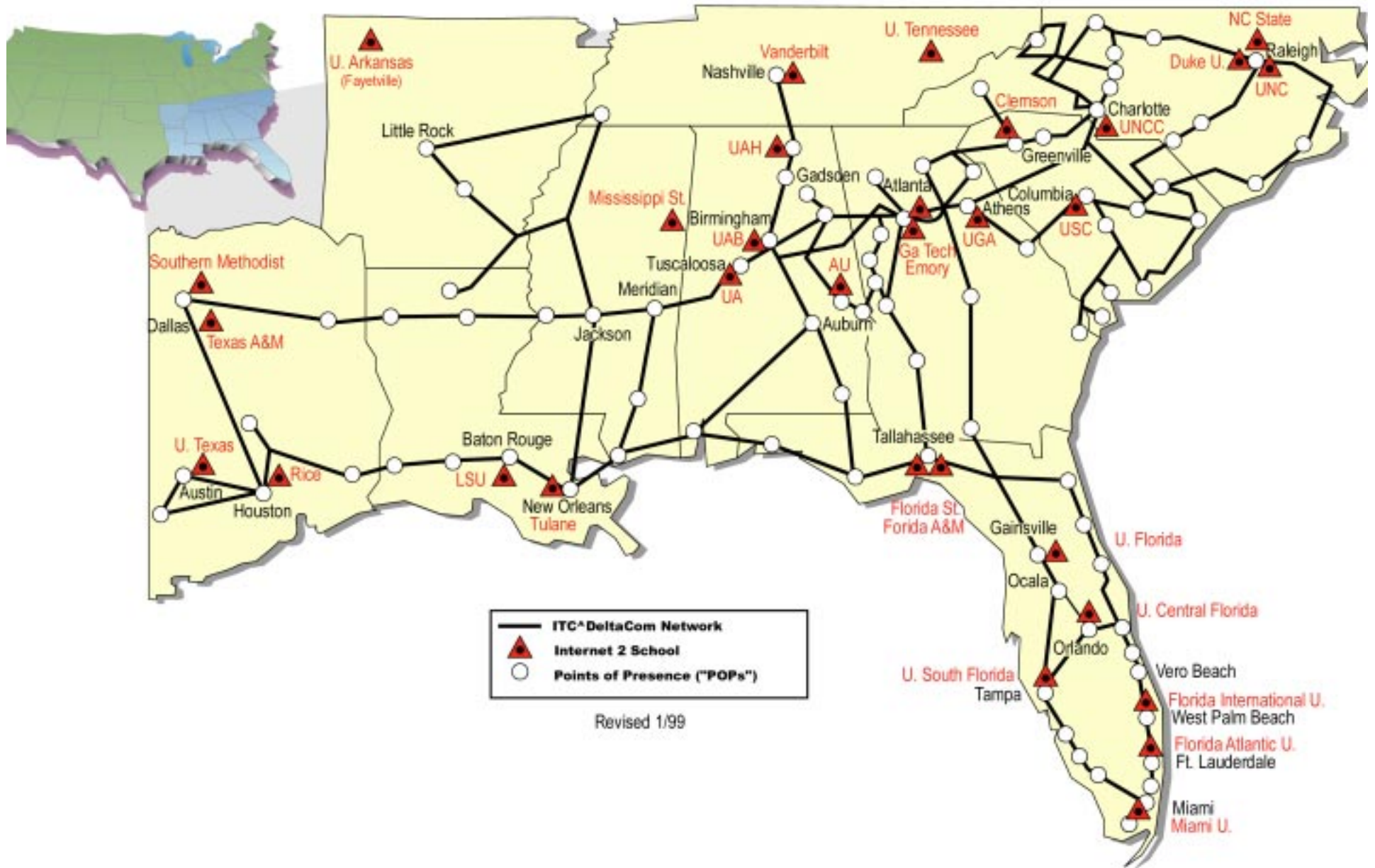



UAH Campus Perspective

Sara Graves
sgraves@itsc.uah.edu



MILESTONES: Summary

- **FUNDED GRANTS**
 - NSF vBNS (UAH/ASA/A&M)
 - EPSCoR
 - NASA Applications
- **GULF CENTRAL GIGAPOP**
 - 3 campus coordination
 - ITC^Deltacom providing circuits
 - ASA providing Network Operations
 - Equipment selection ongoing
- **CITY OF HUNTSVILLE**
- **Huntsville High Performance Network Group (HPNG)**
- **CAMPUS NETWORK INFRASTRUCTURE UPGRADE**
- **NGI APPLICATIONS**
 - Weather and Climate
 - Space Science and Engineering
 - Information Technology
- **UAH I2 WEB SITE**

MILESTONE: High Performance Network Group

- City, State, Federal, and University Networks are represented
- 3 subgroups:
 - Policy
 - Applications
 - Technical
- Huntnet currently being built



MILESTONE: UAH I2 Web Site

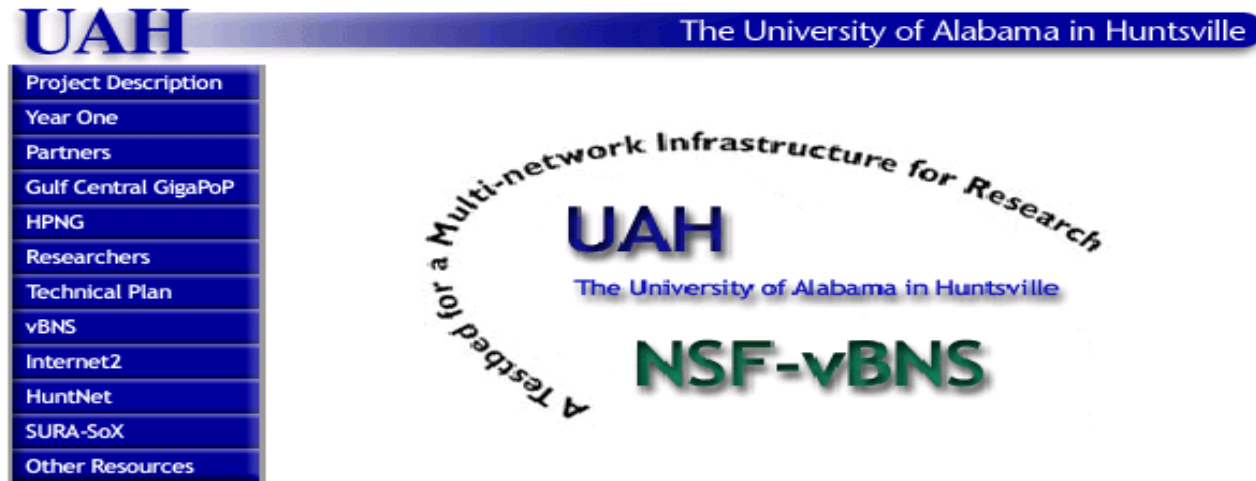

Technical Vision: Seamless Collaboration

Advancing technology has brought the world closer. This is especially apparent in the ever-expanding role of communications networks. These networks will continue to evolve, and their success will hinge, in part, on the development of seamless access to a variety of computational and information networks. The end users of the networks of tomorrow should become even less aware of the degree to which they are using one or another particular network. These networks will have various demands

www.itsc.uah.edu/vbns

MILESTONE: APPLICATIONS

- Weather and Climate
 - Global Hydrology and Climate Center - climate research, data subsetting and distribution
- Space Science and Engineering
 - Ultraviolet imager; real-time auroral imaging investigation
- Information Technology
 - Collaborative Multi-Archive Data Mining
 - Distributed Knowledge Networks

MILESTONE: Local Loops

- City of Huntsville donated fiber
- Two UAH locations
 - UAH main campus
 - Global Hydrology and Climate Center
- Alabama Research and Education Network



UAB Campus Perspective

David Shealy
dls@uab.edu



NSF-NLANR Active Monitor Program for vBNS

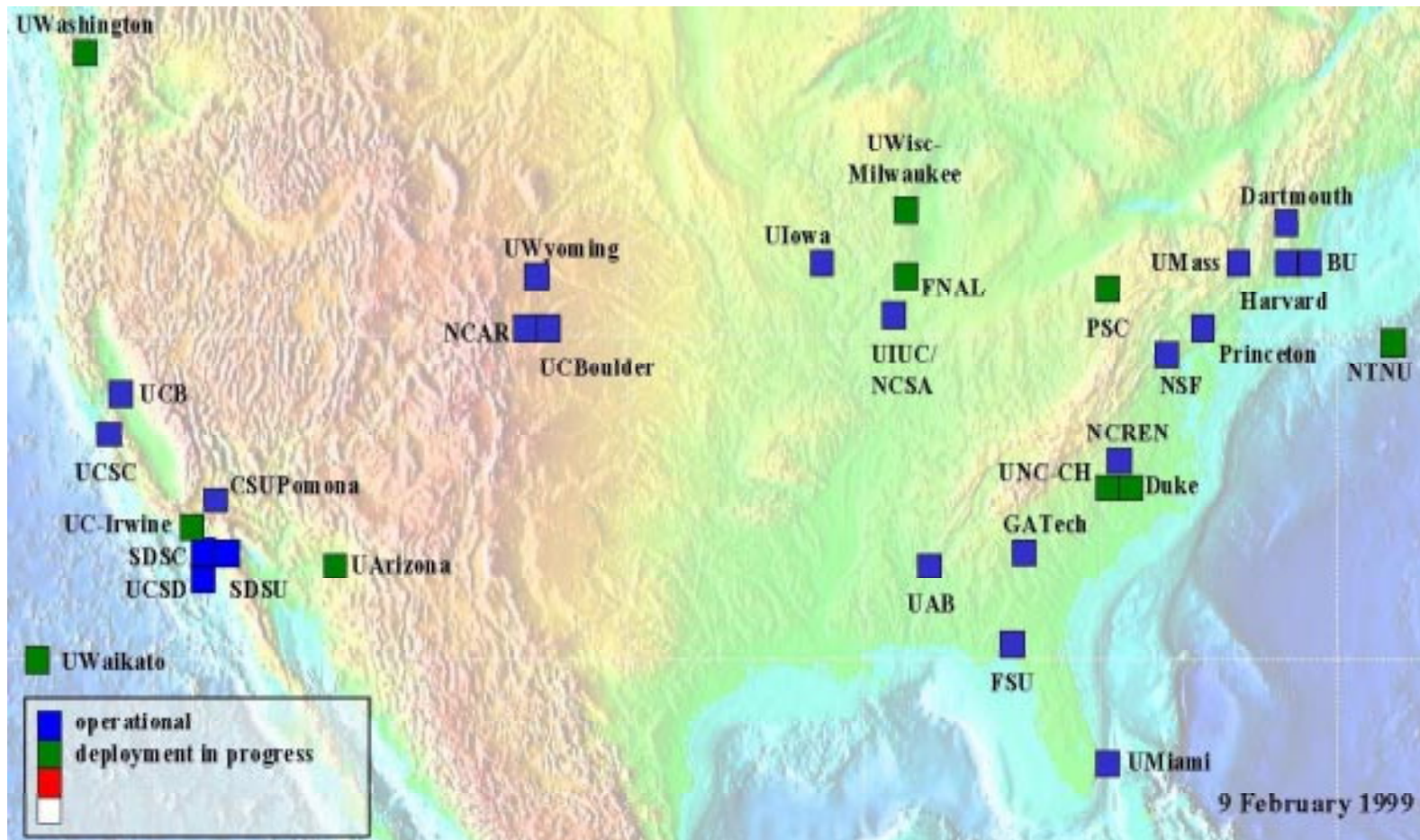

<http://moat.nlanr.net/Images/actsites.jpg>

MILESTONES: Summary

- **FUNDED GRANTS**
 - NSF vBNS
 - EPSCoR
 - HSF
- **GULF CENTRAL GIGAPOP**
 - 3 campus coordination
 - RFP
- **LIVE CONNECTION TO vBNS/SOX NETWORKS**
- **CAMPUS NETWORK INFRASTRUCTURE UPGRADE**
- **CAMPUS NETWORK EQUIPMENT**
 - Equipment Advisory Committee
 - Experimental ATM
- **UAB I2 WEB SITE**

MILESTONE: Live Connection to vBNS/SoX Networks

April/May 1998

Purchased new network equipment and activated 45Mb/s network connection to vBNS and to “Southern Crossroads” (SOX)

MILESTONE: UAB I2 Web Site

UAB **INTERNET²**

CONTENTS

SEARCH

UAB Network Requirements Survey
Tell UAB campus planners about your high performance network requirements

I2 Member Universities

Calendar
Conferences, video presentations, and Workshops

Conferences
Announcements of Conferences on new networking technologies, supercomputing, etc.

Contacts
Internet2 Contacts at UAB

Home

Introduction

Research Application

UAB Survey

NSF vBNS Award

EPSCoR Award

Gulf Central GigaPOP

NLANR

International

National

SouthEast

Alabama

Funding Sources

Presentations

What is Internet2?

Any UAB person interested in I2 may [request access](#) to the Internet2 MEMBERS ONLY area of the national I2 web site.

Web-based Instruction/Distributed Learning

The university-wide Faculty Interest Group on Web-Based Instruction/Distributed Learning has come together to respond to the considerable interest in the academic schools and schools for health-related professionals to explore various platforms for Web-based instruction. The purpose of this Faculty Interest Group on Web-Based Instruction is for faculty to share information, to provide support to each other, and to inform the administration on Web-based instruction related issues, so that interested faculty and administration may make informed choices about future strategies and plans. Contact [Chris Lorish](#) (Medicine) or [Joann Lan](#) (Education)

On-line Video: Advanced Networking: Connecting to the Future is a 5 minute video that highlights the promise and potential of applications made

<http://www.uab.edu/internet2/>



UA Campus Perspective

David Cordes
cordes@cs.ua.edu



UA Internet2 Web Site



[UA I2 Team](#)

[I2 Team Activities](#)

[I2 Activity Schedule](#)

[I2 UA Engineering](#)

[I2 UA Gigapop](#)

[I2 Home Page](#)

[UAB I2 Home Page](#)

Internet2 (I2) is a major national collaborative effort involving over 100 Universities and other industrial and governmental affiliates. The goal of I2 is to construct and operate a research network with greater than 100 times the bandwidth typical of the current internet. As charter members of I2, The University of Alabama (UA) and The University of Alabama at Birmingham (UAB) are leading Alabama and the region to a new era in communication and collaborative technology.

[UA HOME](#)

<http://www.ua.edu/internet2/>

UA Applications

- **MINT: Materials for Information Technology**
- **Astronomy**
- **Distance Learning**
- **Mobile Computing**
- **Pediatric Tele-medicine (joint with UAB)**
- **NASA (Aerospace applications)**
- **Geology**
- **Biomedical Engineering/Mathematics**

EPSCoR Project Contributions

- Provides funding to help connect all research institutions in the State
 - the three institutions in the UAS system
 - Auburn University
 - Alabama A&M
 - Tuskegee University
 - University of South Alabama

Project Goal

High-speed networking infrastructure
available to all researchers in state

? Questions ?